



Americas Hydrogen and Syngas Technical Training Seminar

Water gas shift - low temperature shift and medium temperature shift

Scott Commissaris



Agenda



01 Water gas shift basics and equilibrium curve

02 MTS/LTS & HTS Comparison

03 Catalyst features & challenges

04 Poisons & Methanol

05 Reduction

Water gas shift basics



+ Heat

$\Delta H = -41.1 \text{ kJ/mol}$

Reversible reaction

Exothermic (forward reaction)

- Lower temperature
- Increased CO converted
- Increased hydrogen produced

Equimolar

- Pressure - no effect on equilibrium
- Excess steam – more hydrogen produced

Low temperatures allow a more favourable equilibrium position, but kinetics help drive the rate of reaction at lower temperatures

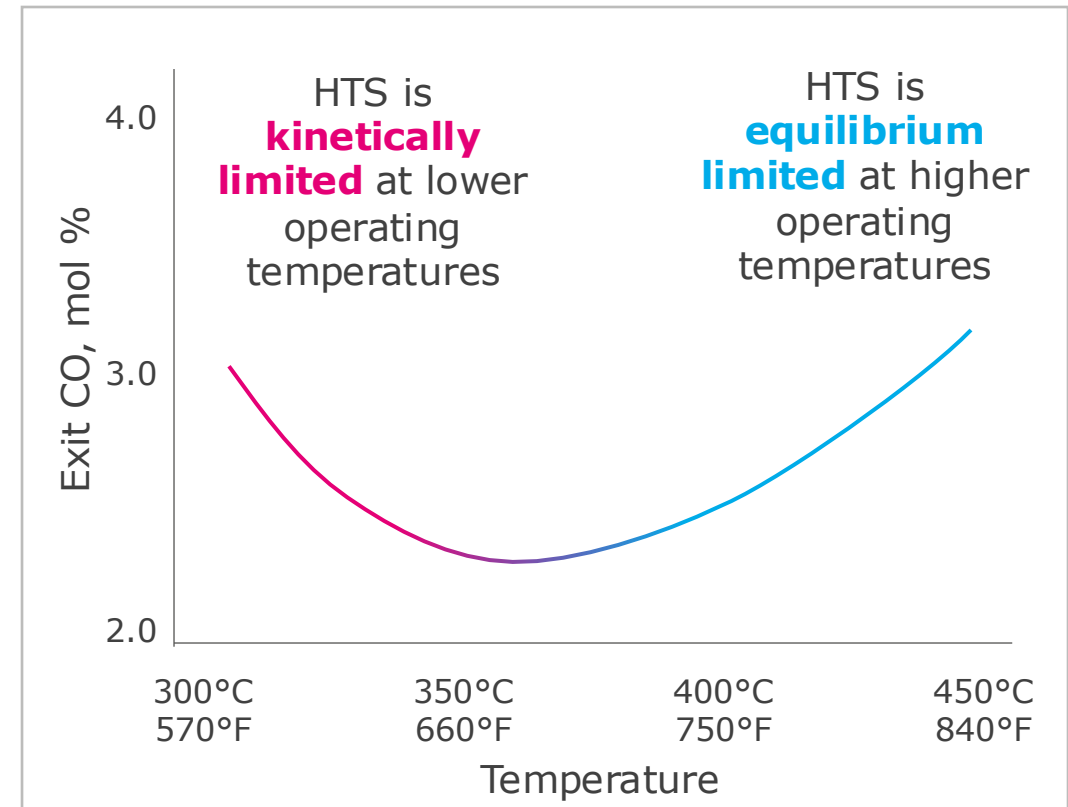

WGS equilibrium

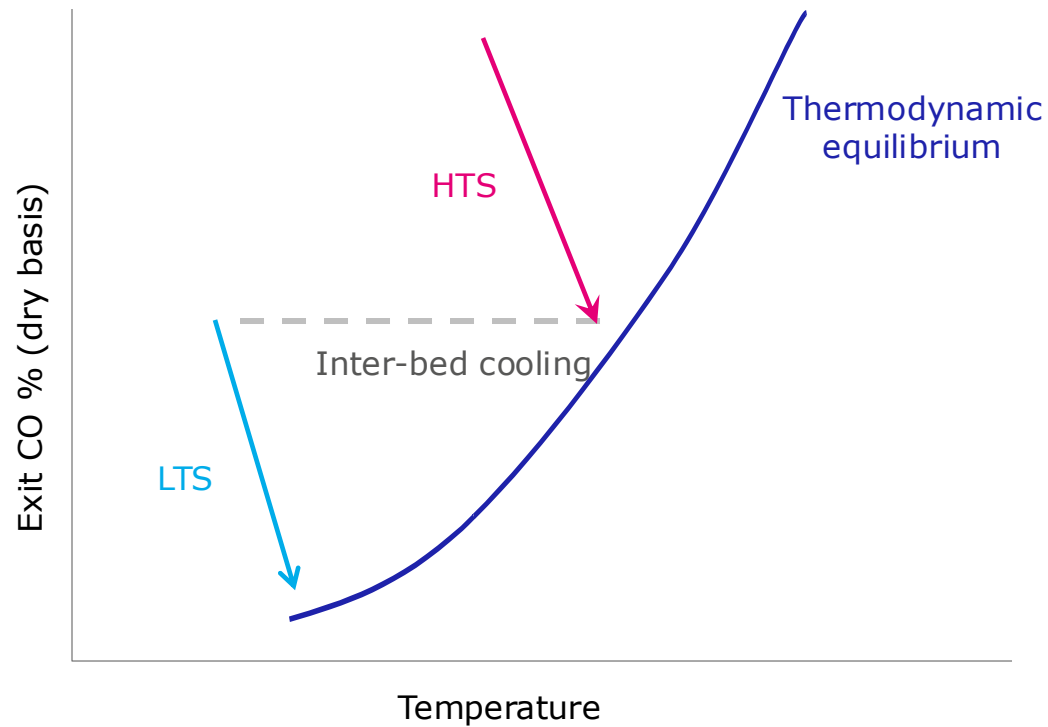

The WGS reaction is exothermic.

As the reaction approaches equilibrium, the rate of reaction slows.

Higher conversion can be achieved by cooling the process gas, and reacting further to a lower equilibrium of CO.

Hydrogen and syngas flowsheets have different WGS unit configurations depending on efficiency and downstream process requirements.

LTS and MTS

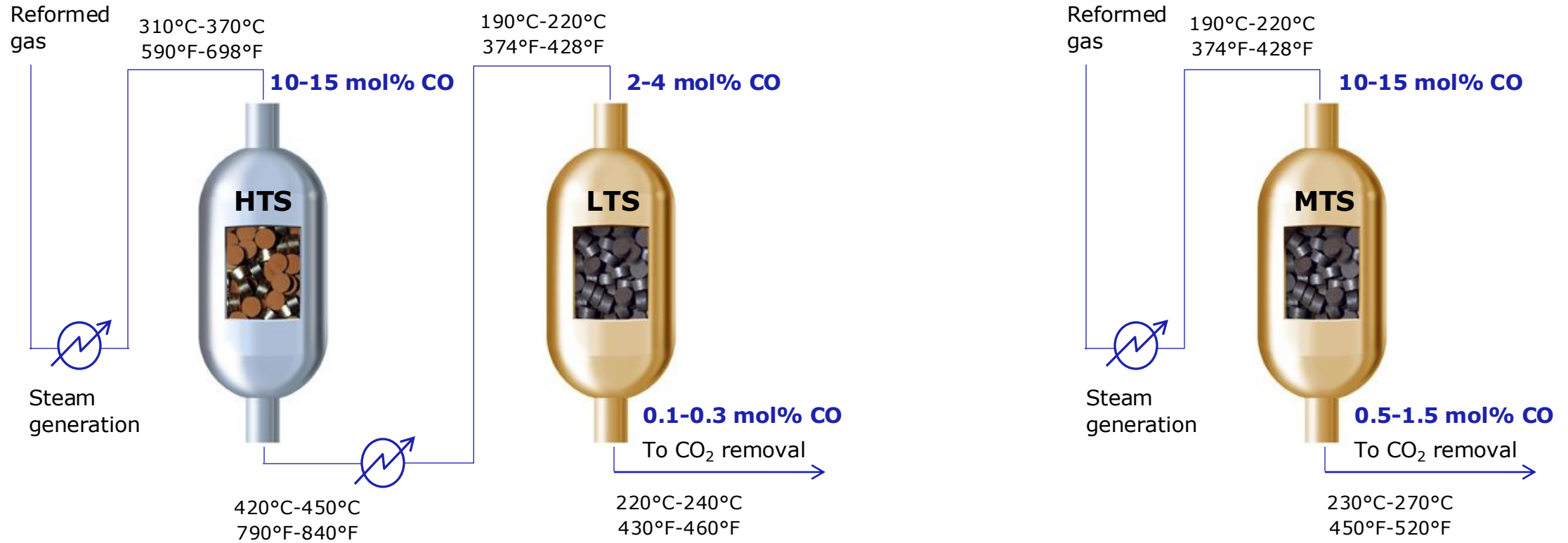

Reduce CO levels and increase H₂ make $\text{CO} + \text{H}_2\text{O} \leftrightarrow \text{CO}_2 + \text{H}_2$ (exothermic)

Advantages and disadvantages of MTS verses HTS in hydrogen plants

Advantages

Lower investment cost

Enabler for low steam:carbon ratio, avoids issues with over-reduction as faced with Fe based HTS catalysts

Reduction in feed rate (~3%) due to higher conversion lower CO slip

Lower CO to PSA

Greater heat recovery in waste heat boiler to achieve lower inlet temperature, thus increased steam export

Disadvantages

More expensive heat recovery, larger BFW heaters required

CuZn based MTS catalyst is more expensive than Fe based HTS catalyst

Potentially shorter lives of CuZn MTS catalyst, as MTS catalysts are affected by both poisoning and sintering effects

Requirements to reduce the catalyst before putting into operation

Lower heating value fuel gas due to higher CO₂

LTS/MTS

Catalyst features

Cu/Zn/Al formulation

High and well dispersed
Cu content

Strong ZnO/alumina
refractory phases

Inhibition of Cu sintering
by the ZnO/alumina phases

**For LTS, control of Cu
activity plus special
promoters increase
selectivity**

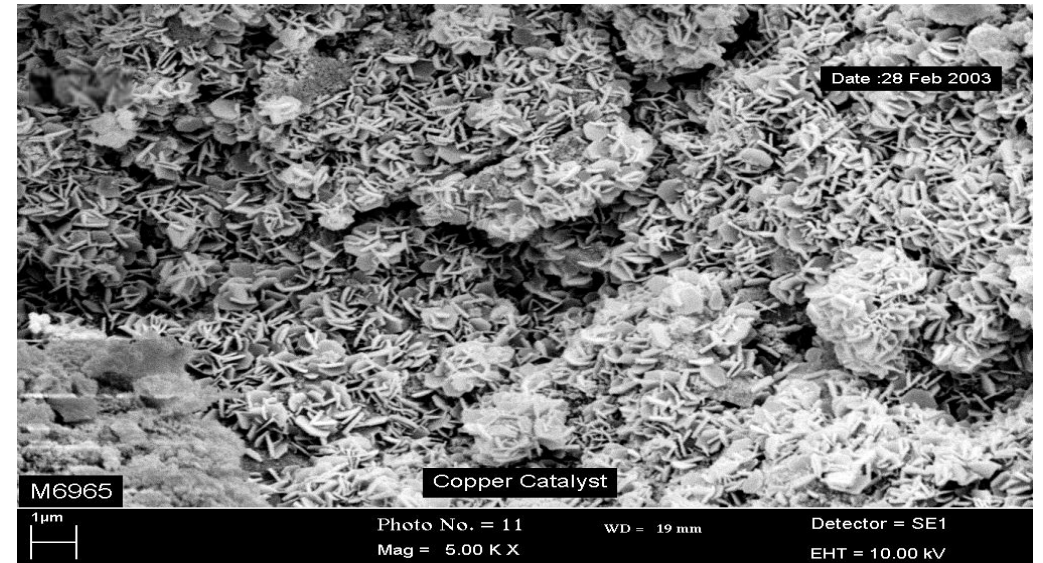
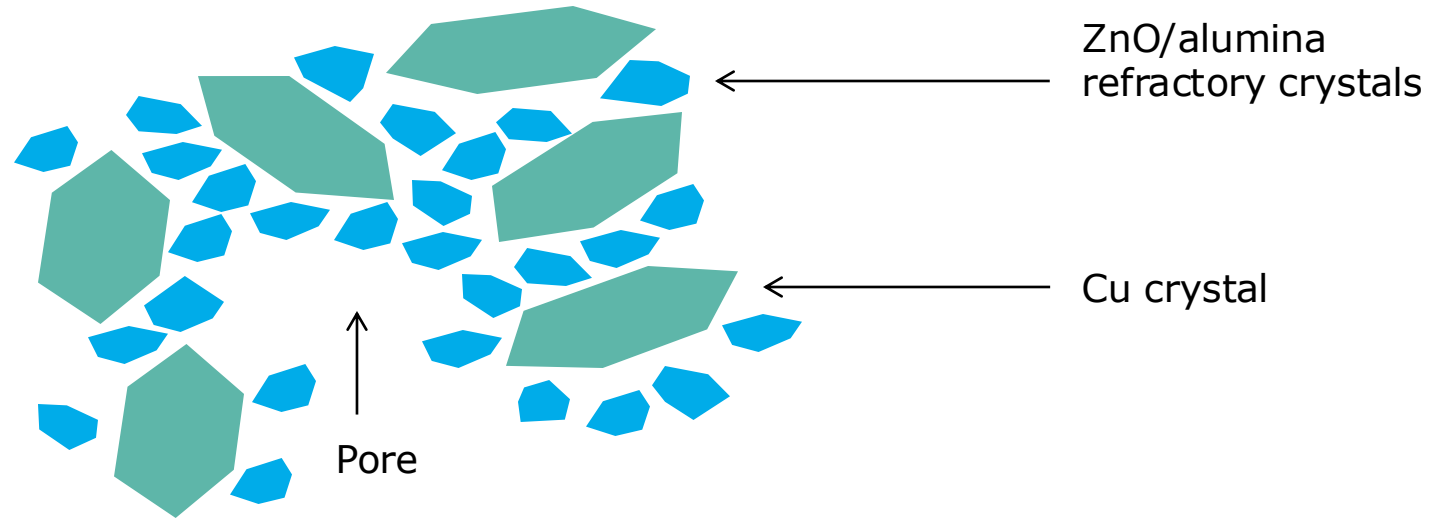

Common challenges with the LTS/MTS operation

Poisoning

- Poisons such as sulfur and chlorides in the feed can lead to faster catalyst deactivation.
- Poisoning leads to frequent catalyst changes and unplanned shutdowns.

Pressure drop increase

- Pressure drop increase occurs from plant upsets such as wetting and condensation
- Increased pressure drop can impact throughput

Condensate and wetting

- LTS and MTS generally operate with inlet temperatures close to dew point
- Condensing on the bed can wash poisons into the bed

Increased methanol by-product formation

- At higher temperatures, by product methanol can be formed
- This can lead to contamination of the vent gas and export CO

Two very different catalyst poisons

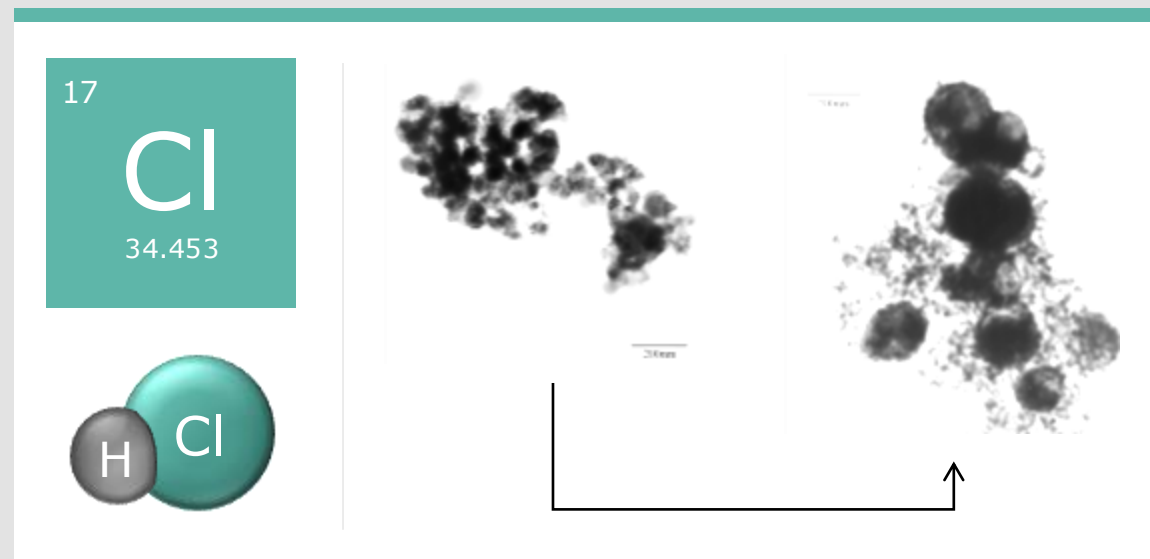
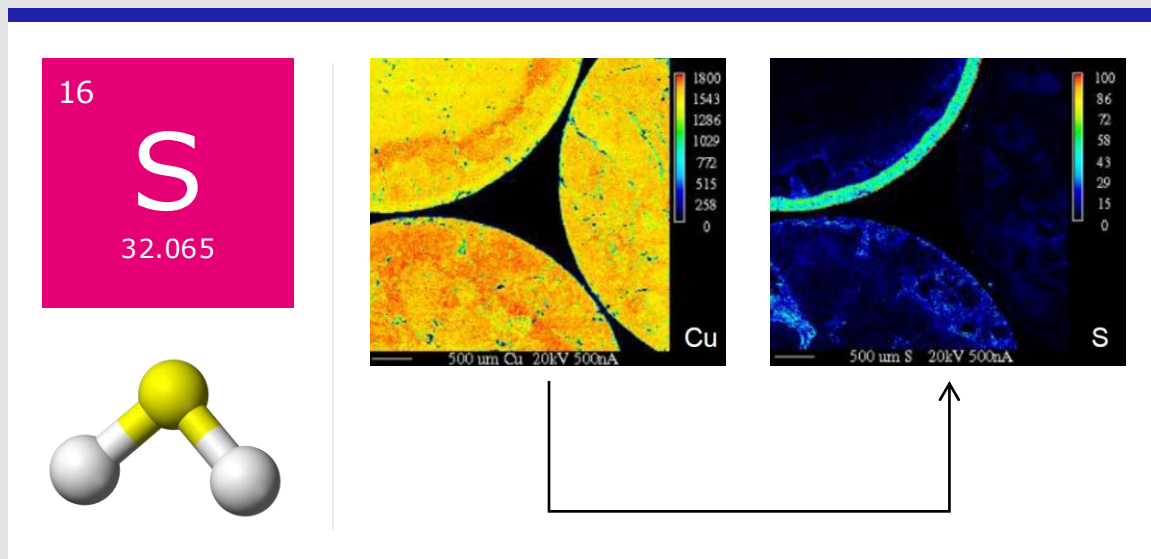

Feedstock



Process air



Insufficient
purification



Lubricating oils



Water additives

Sulphur is the most common poison



S reacts with Cu surfaces forming **CuS**

S surface **mobile**

ZnS thermodynamically stable

Bulk sulphide ZnS the stable endpoint within catalyst

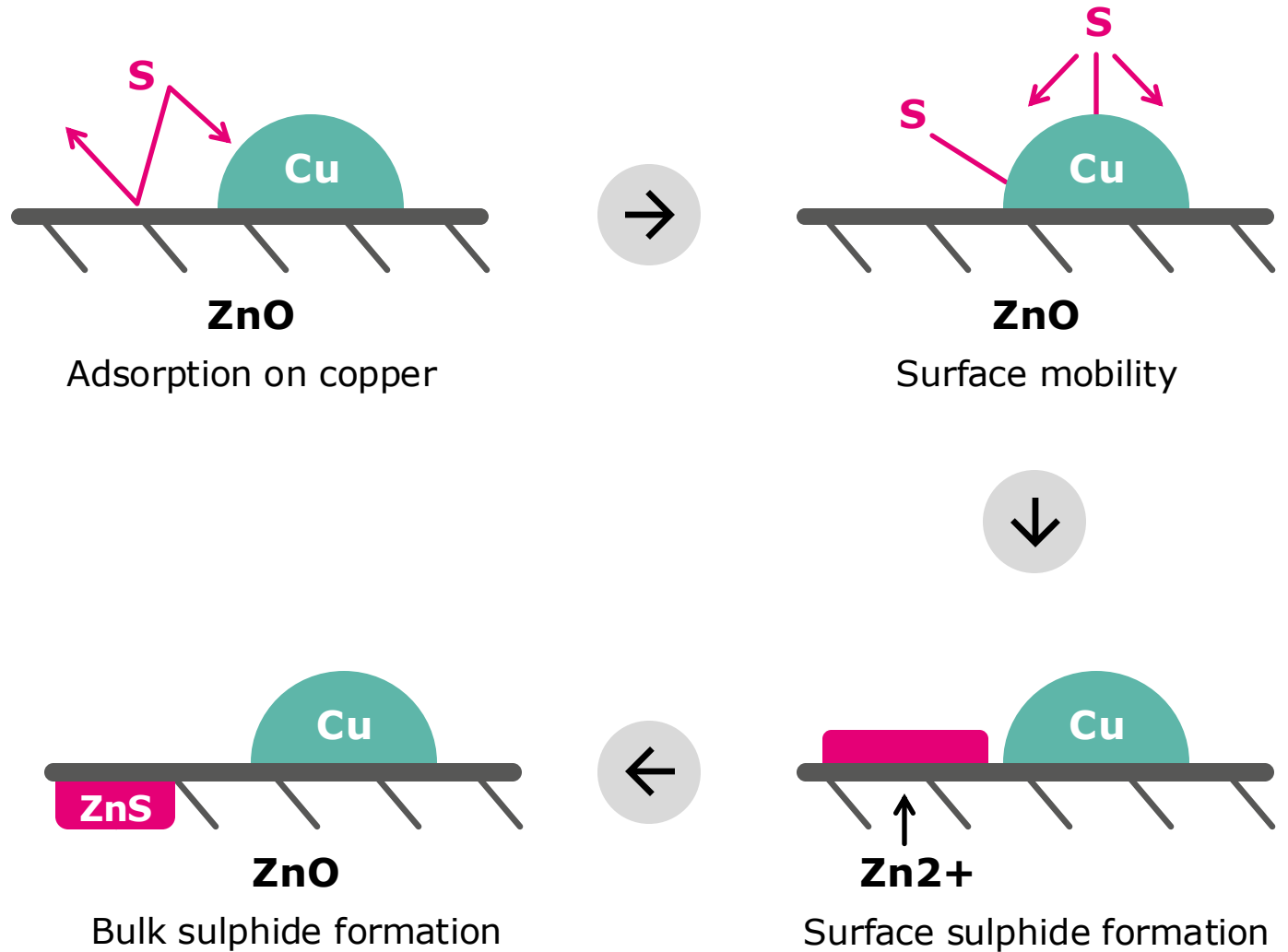

Chlorides strongly promotes sintering

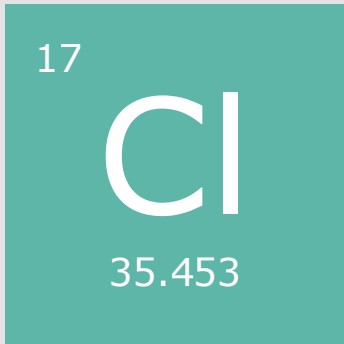

Cl forms **CuCl**

CuCl mobile if **wetted** so **poisons can be washed deep into bed**

CuCl has **low melting point** promotes sintering

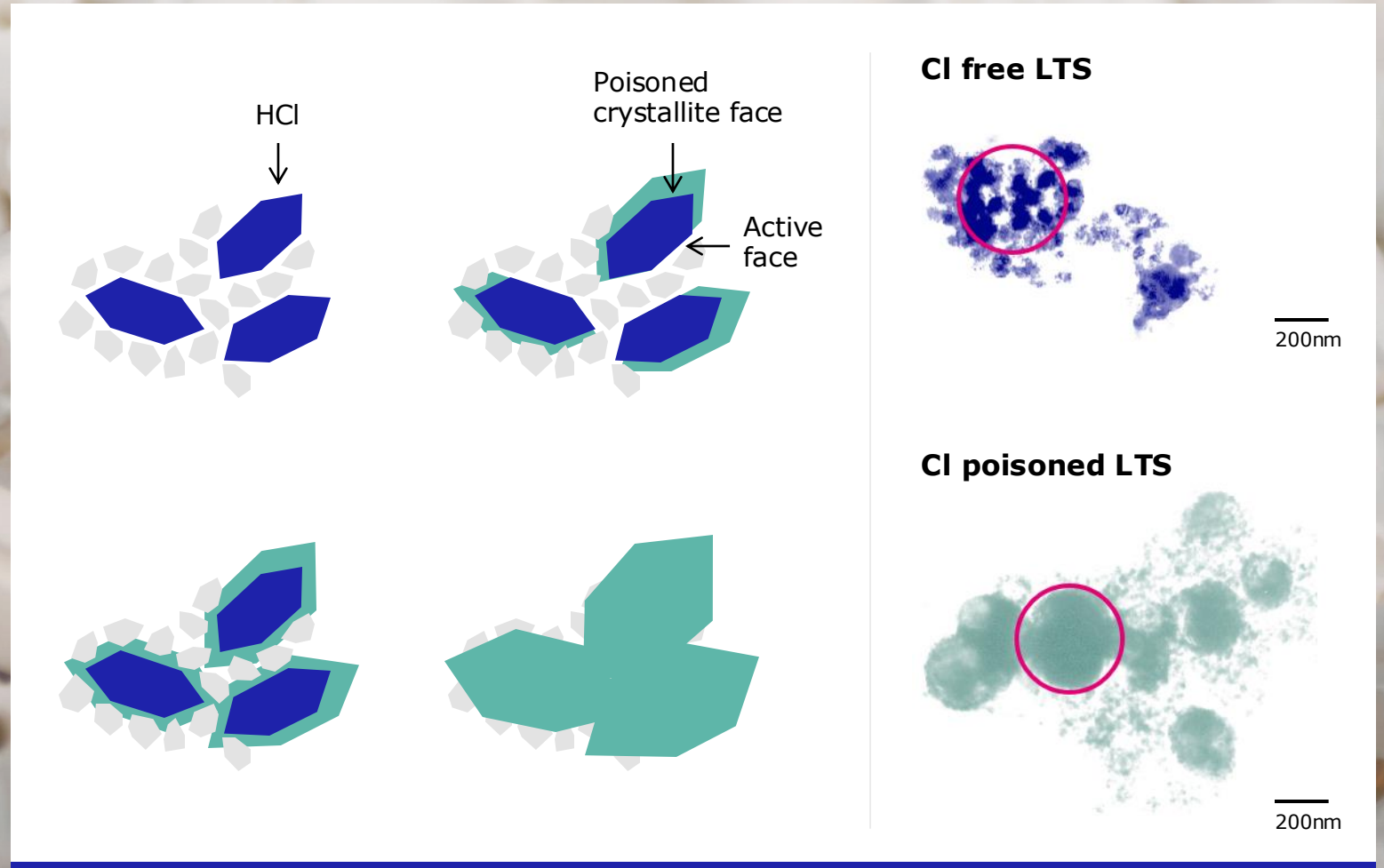

Self Guarding properties for S and Cl

Catalysts such **KATALCO** 83-3 and **KATALCO** 83-5 protect against poisons

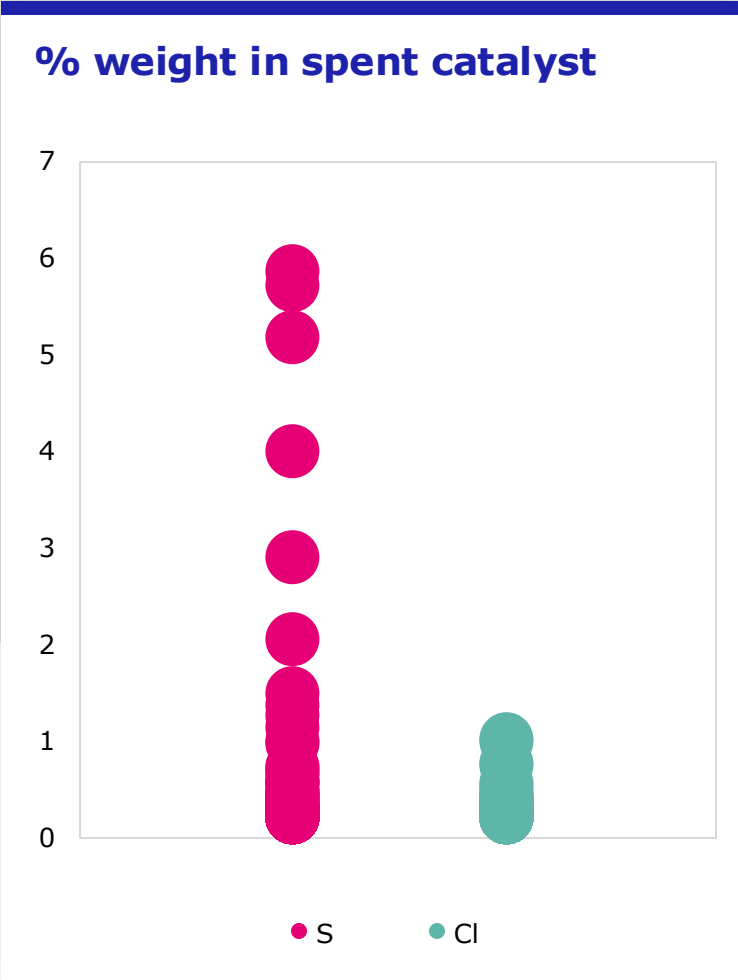
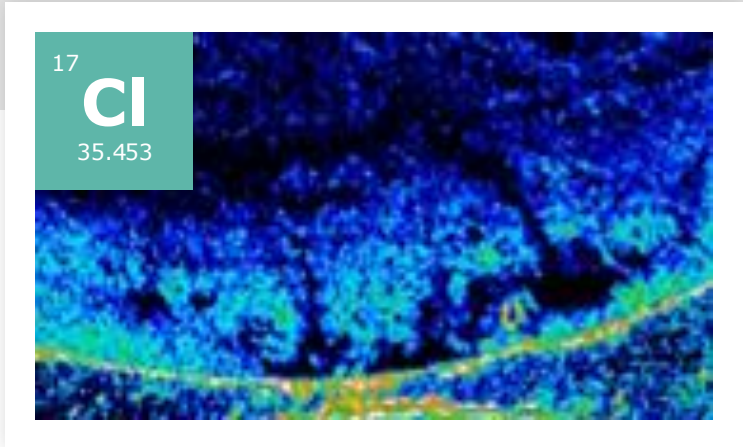
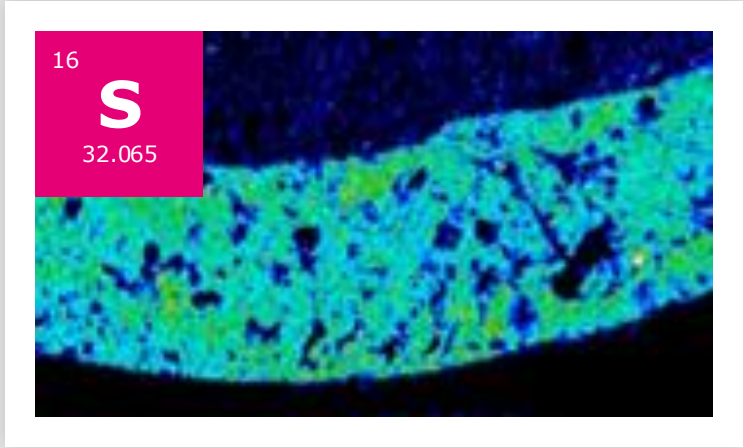
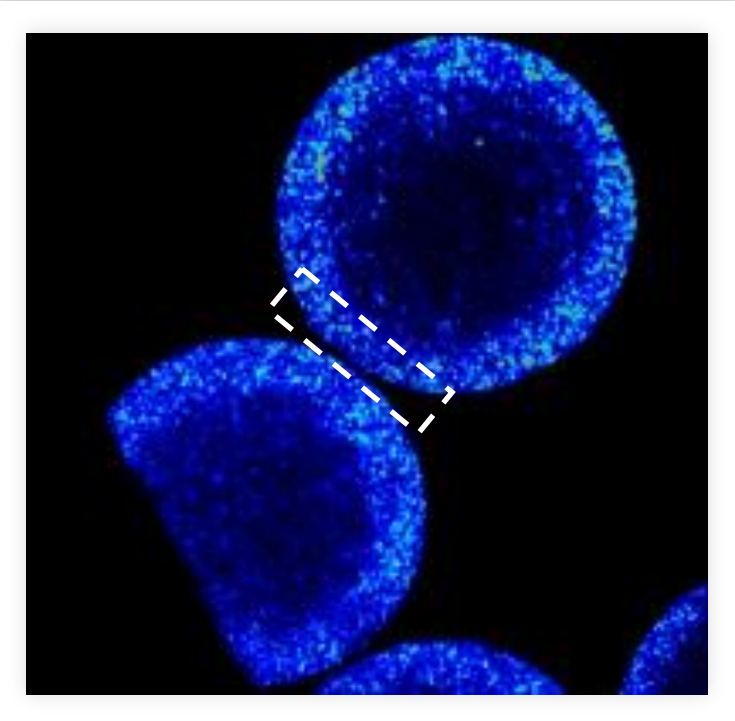

Catalyst poisoning

LTS poisoning profile

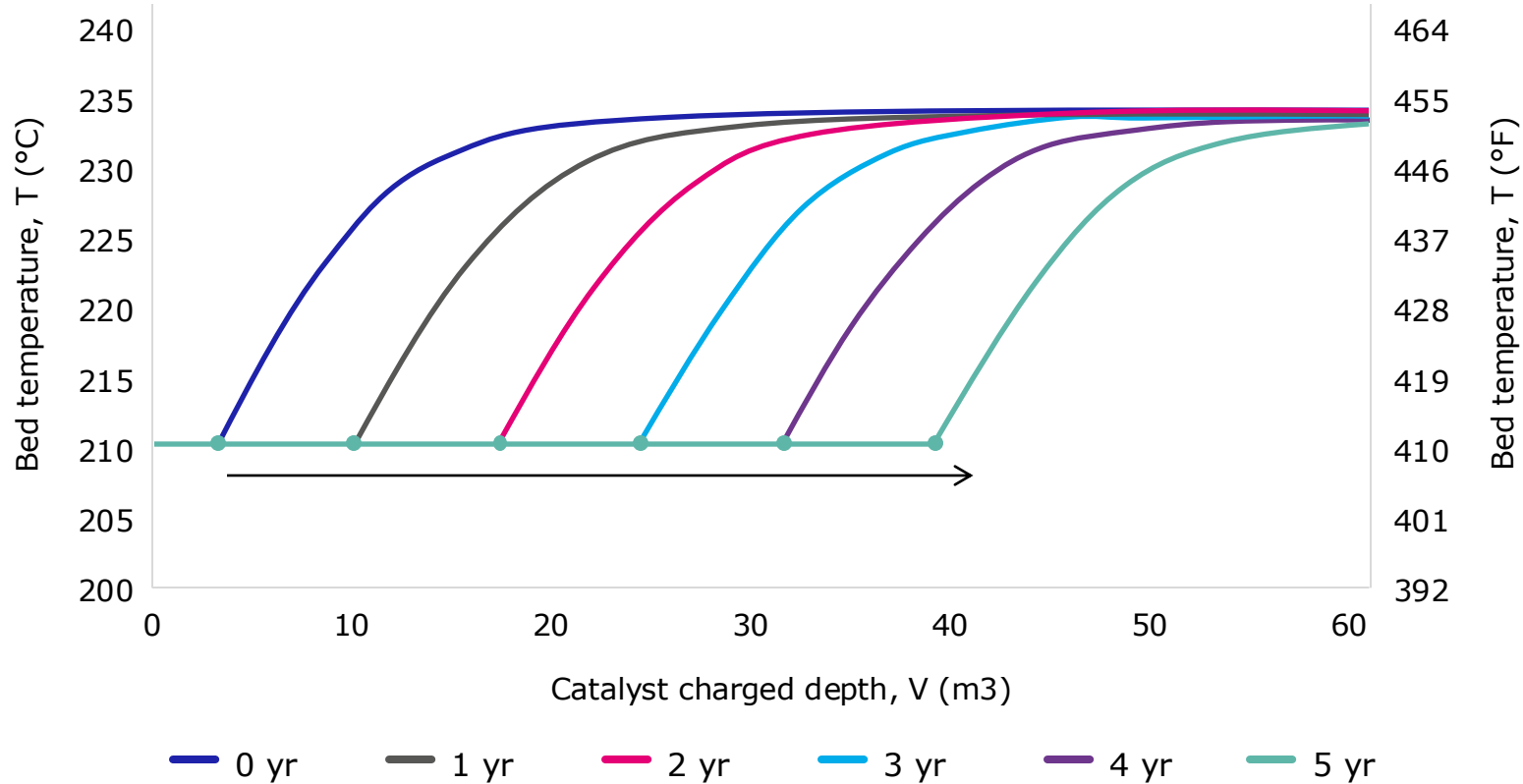

Useful life **largely governed** by poisoning

No reaction occurs in the **poisoned volume**

Poisons may be washed into the bed if **accidentally wetted**, which can impact performance

Poisons retained by the **catalyst prevent** poisoning further down the bed

Thermal sintering may be observed in MTS or LTS units that are operated with long lives

Case Study: Longer lives due to self guarding properties of the catalyst

- Ammonia plant in North America with two similar Kellogg plants without guard
 - One plant: **KATALCO™ 83-3**
 - Lasted 4 years
 - Other plant: competitive catalyst
 - Needed replacement after 2.4 years due to high CO slip
- Operator saved US\$700,000 in replacement costs compared to the previous competitive charge.

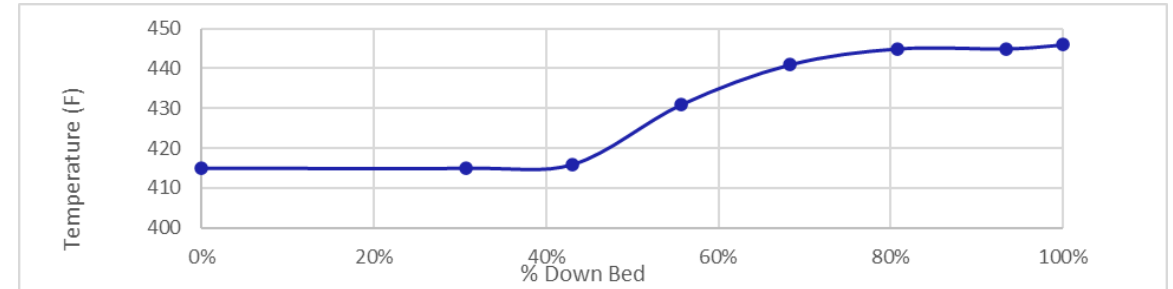

KATALCO 83-3 temperature profile after 3 years on-line

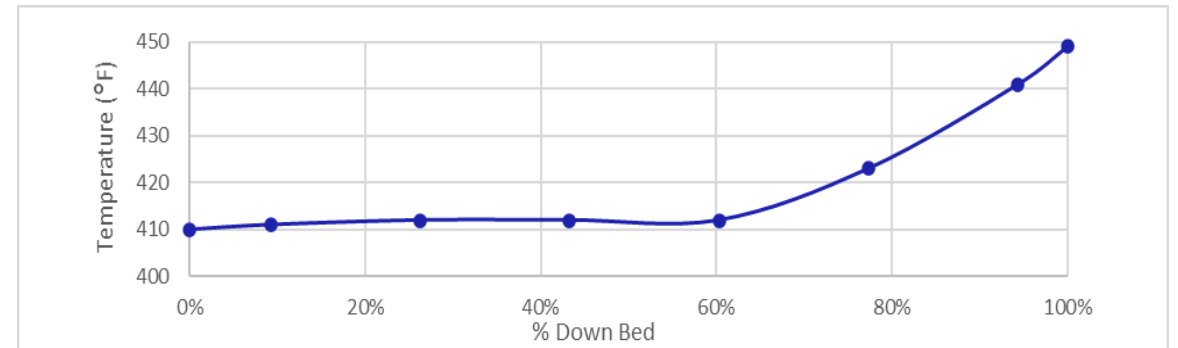

Temperature profile of competitive catalyst after 2 years on-line

Reducing risk of Cl poisoning and transient wetting

JM

PURASPEC 2272:
Protection for Longer LTS Life

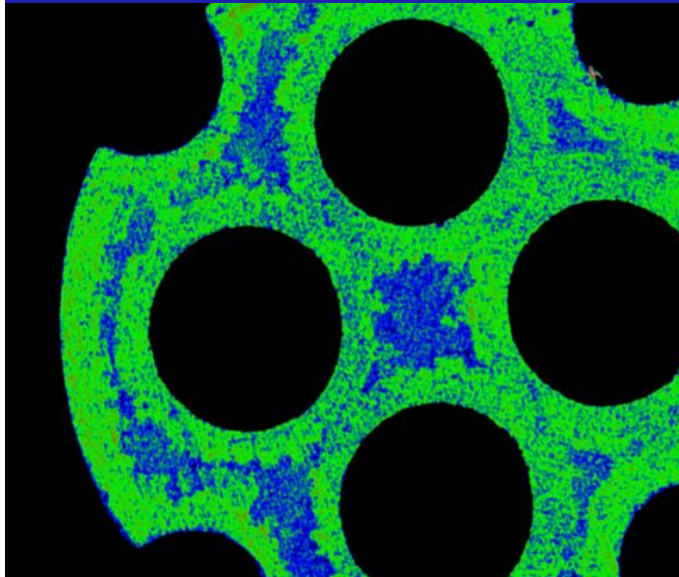
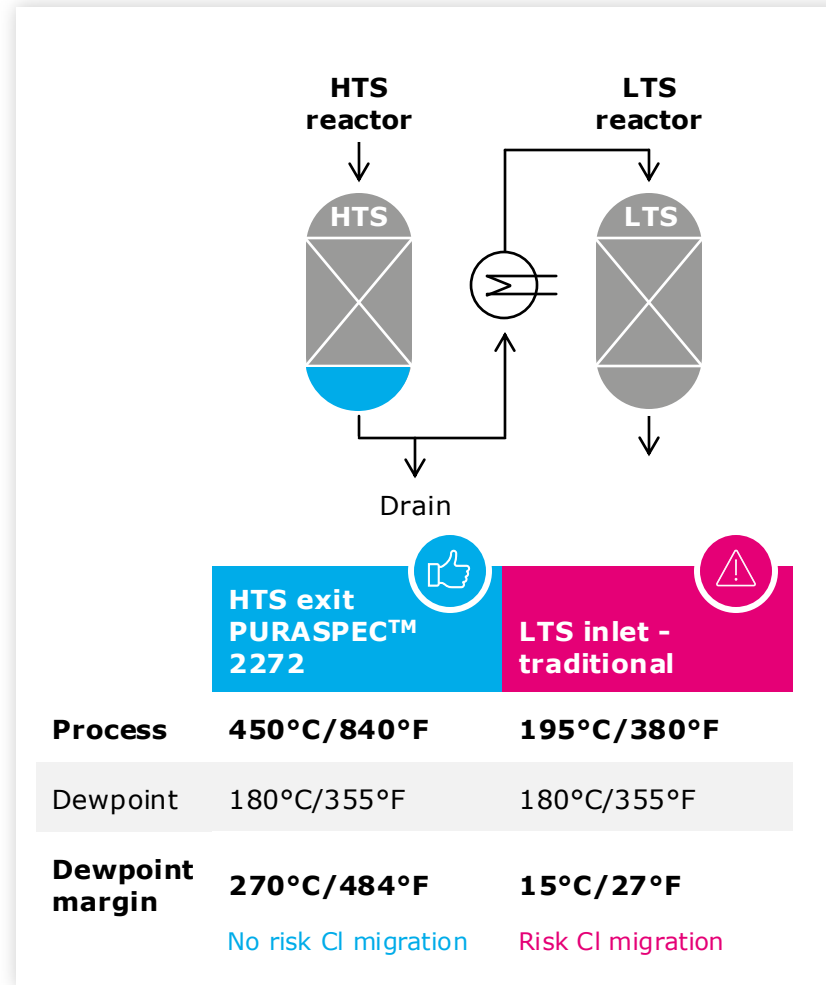
Slower LTS deactivation

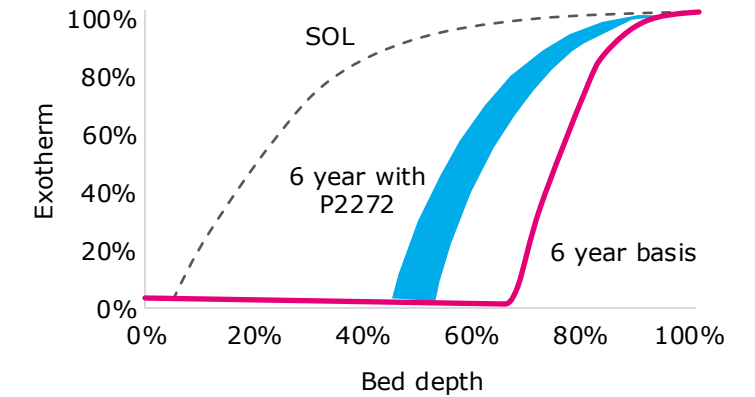

LTS life extension

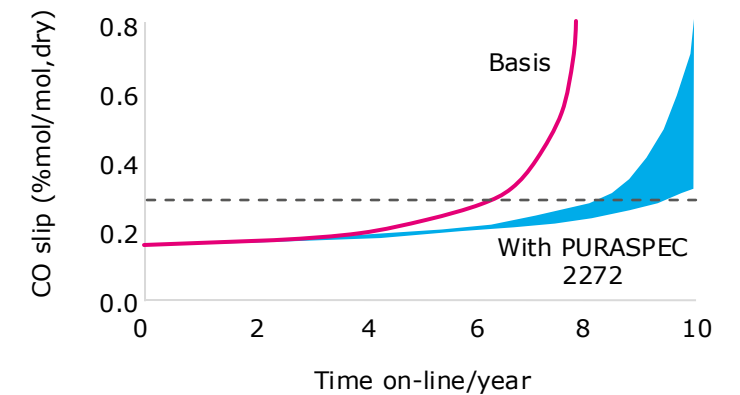

Byproduct methanol production can be an issue for some hydrogen and ammonia plants

- Methanol can be formed in the process condensate, especially at higher temperatures
 - Environmental issue
 - Process inefficiency
- Dedicated catalysts, such as **KATALCO 83-3X**, are formulated with promoters that have improved selectivity and **suppress methanol formation by up to 90% without impacting shift activity**
- Promoters are also effective at retaining trace poisons

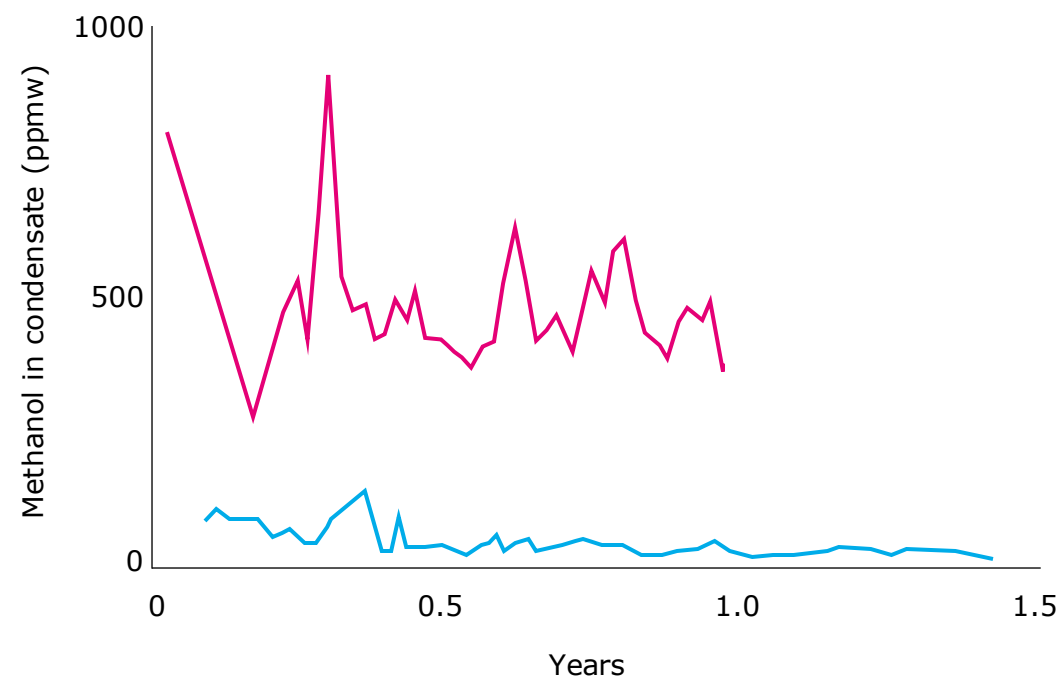

LTS and MTS catalyst activation

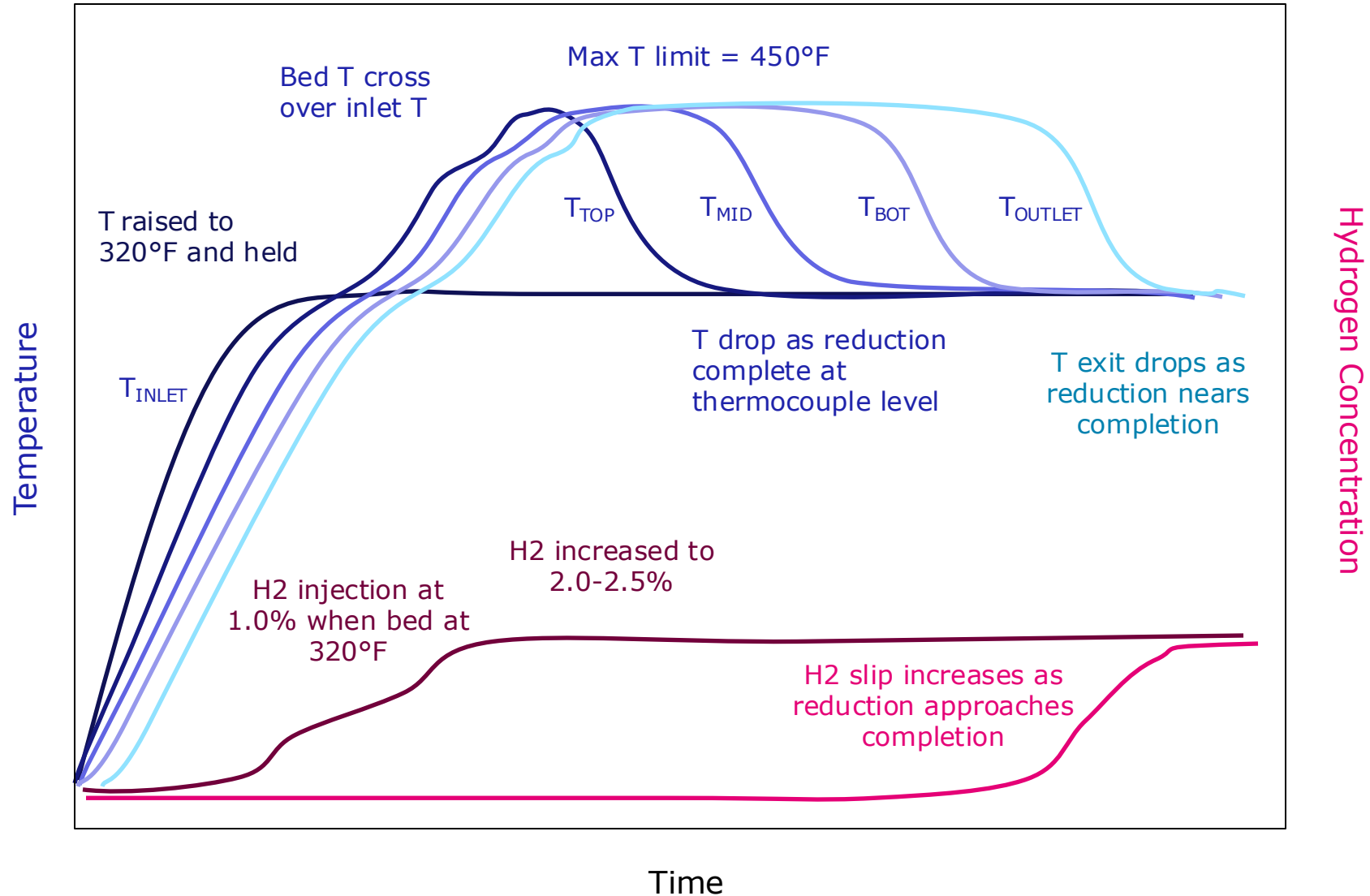

- Drain low points and purge lines
- Start inert gas flow/circulation
- Heat bed, normally 50°C/h (90°F/h)
- Test injection of hydrogen before strike temperature, typically below 100°C (210°F). Confirm good measurement and control of hydrogen.
- Slow heat rate as when bed gets to 120°C (250°F) to 25°C/h (45°F/h)
- With bed at 160°C (320°F), inject 0.5-1.0% hydrogen
- When temperatures stabilize, increase hydrogen to 2.0-2.5%, do not exceed maximum bed temperature of 230°C (450°C)
- Water produced by reaction must be drained from loop
- Reduction will pass through bed, reduction complete when no more reaction and no more hydrogen being consumed, normally reduction takes 36 hours
- Preference for soak after completion, ~4 hours

LTS/MTS catalyst reduction monitoring

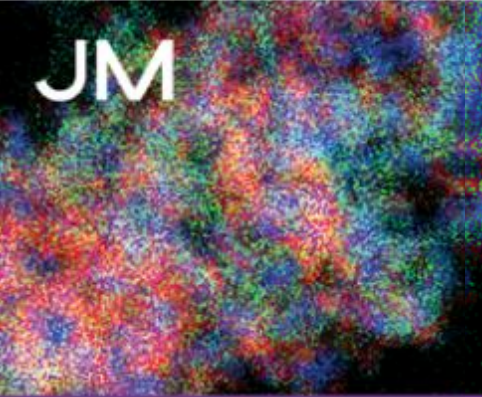

Summary

- LTS/MTS enable more hydrogen production through the water gas shift reaction
- The reduction reaction of the CuZn based LTS/MTS catalyst is very exothermic, and hence needs to be done under controlled conditions before putting the bed into operation.
- The main deactivation mechanism for LTS/MTS is poisoning.
- Regularly monitoring the rate at which the top of the bed is being deactivated through poisoning is good practice.
- Due to the low operating temperatures, care is needed to avoid condensing on the bed. Wetting the catalyst can wash poisons through the bed and impact performance.
- Promoted catalysts reduce byproduct methanol formation.



Leading LTS
stays strong
lowest
pressure drop

www.matthey.com



Johnson Matthey
Inspiring science, enhancing life

JM Johnson
Matthey